

2018 Bulgarian IPhO Team Selection Test

Short Exam 1

Problem. The two ends of a rod of mass m and length l sit on a horizontal floor and on a vertical wall, respectively. The rod lies in a plane which is perpendicular both to the floor and the wall. The acceleration due to gravity is g . Initially the rod is at rest and it makes an angle α_0 with the floor. The rod is let go and starts falling. Ignore friction. The moment of inertia of a rod about an axis passing through its centre of mass perpendicularly to the rod is $I = \frac{1}{12}ml^2$.

- Find the velocity of the centre of mass of the rod v , as well as its angular velocity ω , as a function of the angle α which the rod makes with the floor during its descent.
- At what angle α_1 does the rod lose contact with the wall?
- Find the velocity v_∞ with which the rod will slide on the floor after it has fallen down.

The problem is worth 5 points.

Time: 60 minutes.

Short Exam 2

Problem. Figure 1 shows an asynchronous motor. The rotor is made up of two metal rings attached to the axis, and a large number of rods N which connect the rings. A system of inductors (not shown on the figure) creates a homogeneous magnetic field B perpendicular to the axis of the motor. The inductors are powered by three-phase power, and as a result the magnetic field vector rotates around the axis of the motor with an angular velocity ω .

The radius of the rings is a and the length of the rods is l . Each rod has a resistance R and the resistance of the rings is negligible.

- Obtain an expression for the torque M acting on the rotor when it stays fixed.
- Assume the rotor powers some mechanical device, as a result of which it rotates with an angular velocity ω ($0 < \omega < \omega_0$). Find an expression for the torque in terms of ω . What is the maximum possible mechanical power of the motor P_{\max} ?

Hint: You may want to work in another frame of reference.

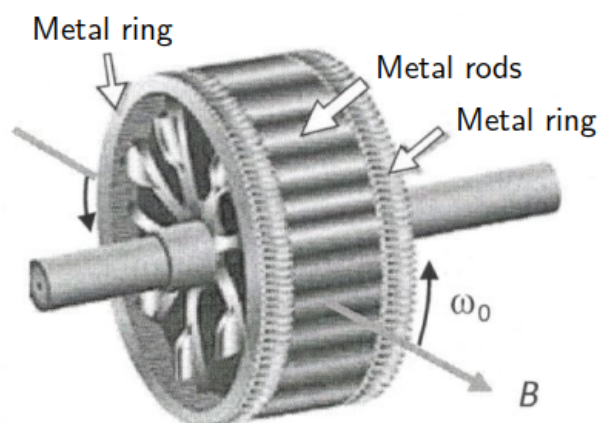

Figure 1

The problem is worth 5 points.

Time: 60 minutes.

Short Exam 3

Problem. An ideal monatomic gas (${}^4_2\text{He}$) composed of bosons is cooled down at constant volume V and constant particle number N . As its temperature decreases, we reach a temperature T_0 below which the properties of the gas arise from the quantum properties of the bosons – i.e. their wavelike nature and their indistinguishability.

- (a) Find T_0 . The wavelike properties become significant when the de Broglie wavelength at the average thermal energy is approximately equal to the mean distance between the particles. Provide a numerical estimate for the number density $n = N/V$ if $T_0 = 4\text{ K}$.

At temperatures $T < T_0$ the particles of the gas can be separated into two groups, each encompassing a nonnegligible number of particles. The first group consists of N_0 particles at the lowest energy level ($\varepsilon = 0$), which do not take part in the thermal motion. The second group consists of N^* particles distributed across various energy levels (with $\varepsilon > 0$). These do take part in the thermal motion, and their number is given by

$$N^* = N \left(\frac{T}{T_0} \right)^{3/2}.$$

This is called a degenerate Bose gas.

- (a) Find the heat capacity of the gas C_V when $T < T_0$. For this temperature range, find the equation of a reversible adiabatic process in the variables T and V .
- (b) Find the pressure of the gas P when $T < T_0$. What is interesting about this result?

Apart from the thermodynamic variables T , V , and N , your results must include the Planck constant h , the Boltzmann constant k , and the mass of the Helium atom, $m_{\text{He}} = 6.7 \times 10^{-27}\text{ kg}$.

The problem is worth 5 points.

Time: 60 minutes.

Theoretical Exam

Problem 1. Two bodies, each of mass $m = 100$ g, are attached to the two ends of a spring with relaxed length $l_0 = 5.00$ cm and spring constant $k = 100$ N/m. The bodies are placed on a horizontal surface, where their coefficient of friction with the surface is $\mu = 1.00$. Initially Body 2 is at rest and the spring is relaxed. Body 1 is imparted a velocity $v_0 = 1.00$ m/s directed towards Body 2.

- Find the maximum extension of the spring Δl during the subsequent motion of the system.
- Find the displacement x_2 of Body 2 between its initial position and its position at the instant when the spring is most extended.

Problem 2. A long horizontal cylindrical pipe of length l and diameter $d \ll l$ rotates with an angular velocity ω about a vertical axis passing through one of its ends. The pipe contains some ideal incompressible fluid of density ρ which forms a column of length l due to the rotation. There are small holes at both ends of the pipe.

- Find a formula for the velocity with which the fluid exits the pipe. Do not account for gravity in this part of the problem.
- Calculate the distance from the axis at which the stream strikes the floor. The pipe is 2 m long and the fluid column is 1 m long. The pipe rotates with a period $T = 0.5$ s at a height $H = 2.0$ m above the floor. Neglect air drag.

Problem 3. The front axle and the rear axle of a car are at a distance $l = 2.0$ m from each other. The centre of mass of the car is at a distance $h = 0.4$ m above the ground, and it is located midway between the front and the rear wheels. When the car is at rest, the suspension spring of each of the wheels is compressed by $\Delta = 10$ cm with respect to its relaxed length. As the car moves, the driver steps on the brakes and the wheels of the car start slipping along the road. The coefficient of friction between the tyres and the road is $\mu = 1.0$. Calculate the angle at which the car's body would tilt with respect to the horizon. The mass of the wheels is negligible.

Problem 4. An infinite sheet is given a uniform charge density σ . A hole of radius a is cut out from the sheet (Figure 2). Find expressions for the electric field at:

- A point A lying on the axis of the hole, at a distance z away from the sheet.
- A point B lying in the plane of the sheet, at a small distance r ($r \ll a$) away from the centre of the hole.

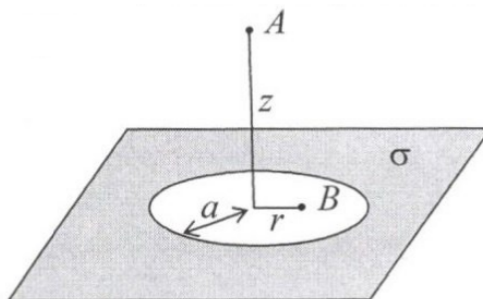

Figure 2

Problem 5. A copper ring of cross-section $S = 1 \text{ mm}^2$ and radius $r = 5 \text{ cm}$ starts rotating around its axis with a constant angular acceleration $\alpha = 1000 \text{ rad/s}^2$. Find the magnetic field B at the centre of the ring. The resistivity of copper is $\rho = 1.68 \times 10^{-8} \Omega\text{m}$.

Hint: You may want to work in the reference frame of the rotating ring. What is the force that gives rise to an EMF in the ring?

Problem 6. A source of monochromatic light (of wavelength $\lambda = 532 \text{ nm}$) is placed at a distance $a = 4 \text{ cm}$ from a lens of radius $R = 2 \text{ cm}$ and focal length $f = 3 \text{ cm}$ (Figure 3). A screen is placed in the focal plane on the other side of the lens.

- Find the radius r of the illuminated spot on the screen. You can neglect the diffraction from the rim of the lens.
- A thin plate of thickness $d = 20 \mu\text{m}$ and refractive index $n = 1.5$ is put between the source and the lens, perpendicularly to the optical axis of the lens (Figure 4). The illuminated spot on the screen turns into alternating concentric bright and dark rings. Find the number of bright rings N .

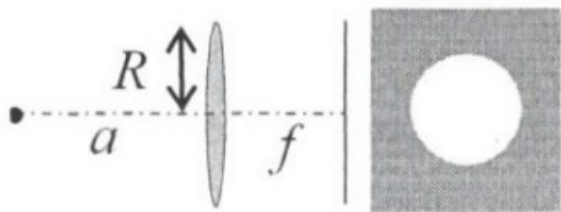

Figure 3

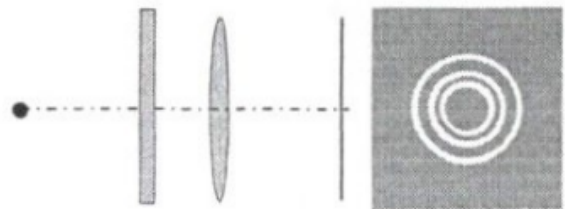

Figure 4

Problem 7. A particle of rest mass m starts moving under a constant force F .

- Find the total distance covered by the particle in the lab frame until it reaches a velocity $v = 0.8c$, where c is the speed of light in vacuum.
- Find the proper time taken for the particle to reach a velocity $v = 0.8c$.

Problem 8. A mole of ideal gas is put in a vertical cylinder under a light freely moving piston. The pressure of the gas is p_0 and its temperature is T_0 . Compare the final temperatures T_1 and T_2 of the gas at the end of the following processes:

- The external pressure increases (or decreases) from p_0 to p instantaneously.
- The external pressure increases (or decreases) from p_0 to p slowly.

The gas is thermally insulated and it has an adiabatic index of γ .

Problem 9. A monatomic ideal gas is subjected to a process where the number of collisions Z between the atoms per unit volume per unit time remains constant.

- Find how Z depends on the pressure of the gas p and the temperature of the gas T .
- Find the equation of the process in terms of p and V .
- Find the molar heat capacity of the process C .

Problem 10. Using Heisenberg's uncertainty principle, estimate the minimum diameter d of the spot which an electron beam makes on a screen, given that the electrons take $\tau = 10^{-8}$ s to get from the collimator (a circular opening) to the screen.

Constants:

Acceleration due to gravity	g	10.0 m/s^2
Boltzmann constant	k	$1.38 \times 10^{-23} \text{ J/K}$
Vacuum permeability	μ_0	$4\pi \times 10^{-7} \text{ N/A}^2$
Elementary charge	e	$1.6 \times 10^{-19} \text{ C}$
Electron mass	m_e	$9.11 \times 10^{-31} \text{ kg}$
Planck constant	h	$6.63 \times 10^{-34} \text{ J s}$
Reduced Planck constant	\hbar	$1.05 \times 10^{-34} \text{ J s}$

Each problem is worth 3 points.

Time: 5 hours.

Experimental Exam

Problem 1. Measuring the density of irregular-shaped bodies.

Equipment:

Kitchen scale ($m < 500\text{ g}$!), stand, binder clip, glass cylinder, plastic cup, stopwatch, ruler, tape measure, bottle with 1.5l of tap water, scissors, funnel, string, graph paper, and the following five bodies:

1. Fishing sinker (grey ball with a channel through the diameter)
2. Hinge from a cupboard (grey, rectangular, with 4 holes)
3. White piece of metal
4. Reddish piece of metal
5. Bouncy ball with a smiley face

Some of the equipment is shown on Figures 5 and 6. Record all measurements in tables. Write down your results in the answer sheet.



Figure 5

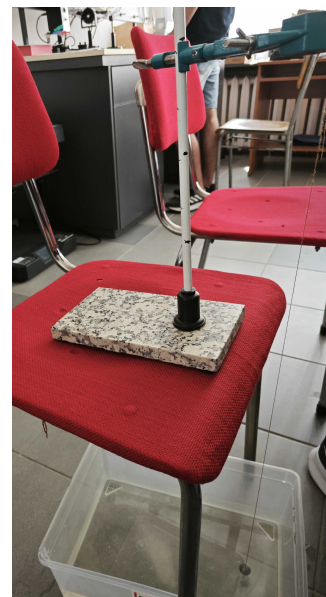

Figure 6

Task 1. Measurements with a scale.

- (a) Devise a method for measuring the density ρ_b of irregular-shaped bodies (without having to calculate their volume in advance) using the readings of the scale in the following cases:
1. The body is placed directly on the scale (m_s).
 2. The body is left at the bottom of a plastic cup filled with water (m_b).
 3. The body is tied on a string and is fully submerged in water, but it does not touch the bottom of the cup (m_s).

The density of water is ρ_w . Find the formula $\rho_b = f(\rho_w, m_s, m_b, m_s)$. **(1.0 pt)**

- (b) Take enough good measurements and calculate the density of each body. **(4.0 pt)**

Task 2. Measurements with a stopwatch.

Make a simple pendulum of length $l \approx 0.7\text{ m}$ using the stand, the clip, the sinker, and some string.

- (a) Measure the periods of oscillation T_a and T_w when the sinker is in the air and when the sinker is underwater (inside the glass cylinder). **(1.5 pt)**
- (b) Assume that the drag forces in both media have no effect on the oscillation periods. Find a formula for the density of the sinker $\rho_b = f(\rho_w, T_a, T_w)$. Calculate this density and compare it to your result in **1(b)**. **(1.0 pt)**

Task 3. Measurements with a stopwatch and a ruler.

- (a) Measure the dependence of the amplitude of the pendulum $A(t)$ on time when it oscillates in air and in water, $A_a(t)$ and $A_w(t)$ respectively. Assume that this dependence is of the form $A(t) = A(0)e^{-\gamma t}$. Using appropriate plots, find the damping coefficients γ_a and γ_w . **(5.0 pt)**
- (b) For a given pendulum, let the period of damped oscillations with coefficient γ be T , and the period of undamped oscillations be T_0 . These are related by

$$T_0 = \frac{1}{\sqrt{\frac{1}{T^2} + \left(\frac{\gamma}{2\pi}\right)^2}}.$$

Use the data from **2(a)** and **3(a)** to find T_{a0} and T_{w0} , the oscillation periods of the pendulum in air and in water if there were no damping. Calculate the density of the body $\rho_{b0} = f(\rho_w, T_{a0}, T_{w0})$ again. Has your result improved compared to the one you obtained in **2(b)**? **(1.0 pt)**

Task 4. Working with a different model.

- (a) The oscillations are exponentially damped only if the drag force is proportional to the velocity, which is typical of low Reynolds numbers, $\text{Re} < 1$. At large Reynolds numbers ($\text{Re} \gg 1$) the drag force is proportional to the square of the velocity instead. Then, assuming weak damping, the angular amplitude of a simple pendulum depends on time as follows:

$$\alpha(t) = \frac{\alpha(0)}{1 + \alpha(0)\delta t}.$$

Using your measurements for oscillations in water from **3(a)**, make an appropriate plot and use it to find δ . **(1.0 pt)**

- (b) For quadratic drag $F_{\text{dr}} = bv^2$ acting on a ball of cross-section S in a medium of density ρ , the coefficient b is given by $b = \frac{1}{2}C\rho S$. The constant C is called a drag coefficient. If b and δ from **4(a)** are related by $\delta = \frac{8}{3}\frac{bl}{mT}$ (l is the length of the string, m is the mass of the bob, T is the oscillation period), find C for your experimental setup. **(0.5 pt)**

Problem 2. Black box.

Equipment:

1. Black box with three numbered terminals (Figure 7)
2. Multimeter ($\times 1$)
3. Stopwatch ($\times 1$)
4. Graph paper ($\times 2$)
5. Ruler, blank paper

The black box contains three components in a Y-connection – a battery, a resistor, and a capacitor, as shown on Figure 8. Each terminal of the black box leads to the free end of a component. You do not have access to the centre of the Y-connection. Initially the capacitor is either completely discharged or left with a voltage less than 0.5 V.

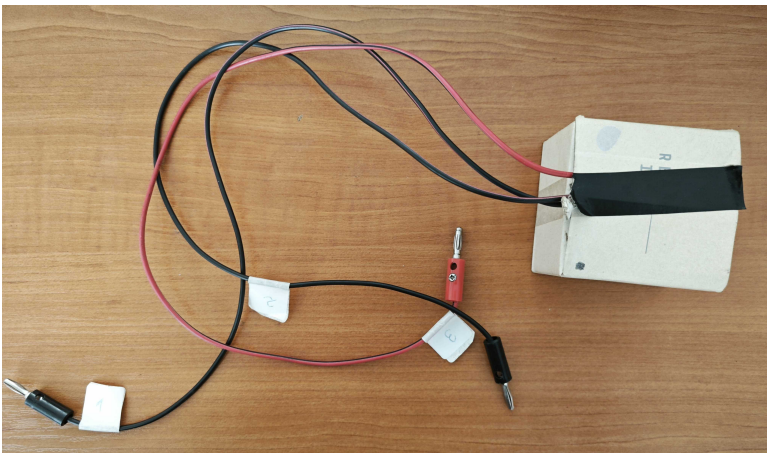

Figure 7

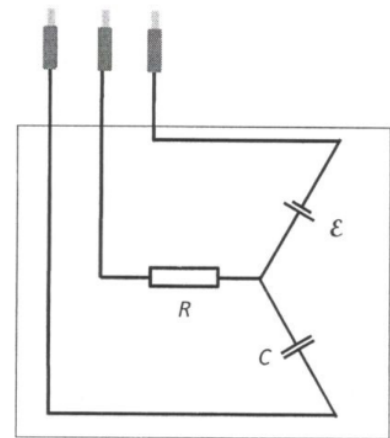

Figure 8

Tasks:

- (a) Describe the measurements that you will have to make in order to find out which terminal is connected to which component.
- (b) Take the appropriate measurements and sketch the circuit inside the black box, indicating the numbers of the terminals corresponding to each component. Also indicate which end of the battery connects to the terminal.
- (c) Write down the relevant theory and take the appropriate measurements so as to find values for:
 - the EMF of the battery \mathcal{E}
 - the capacitance C
 - the resistance R .
- (d) Estimate the errors in \mathcal{E} , C , and R .

You can neglect the internal resistance of the battery and the internal resistance of the multimeter in ammeter mode. The internal resistance of the multimeter in voltmeter mode is not infinitely large and you must treat it as a separate load in the circuit.

*Each problem is worth 15 points.
Time: 5 hours.*